

KWICKSCREEN®

Duo V3

User Manual

Welcome to your new KwickScreen Duo!

Everything you will need to assemble your KwickScreen is listed here.

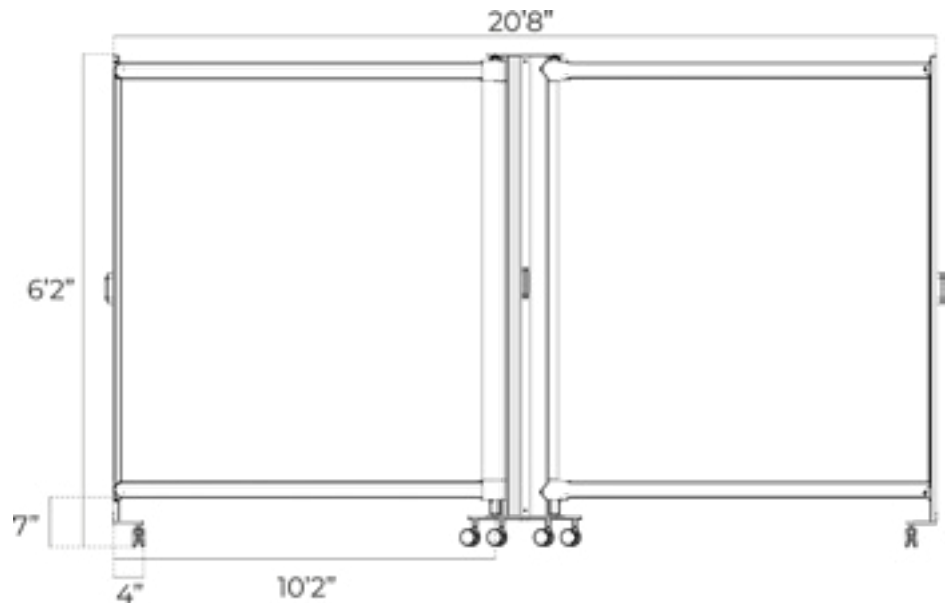

Parts List:

Main Body x1

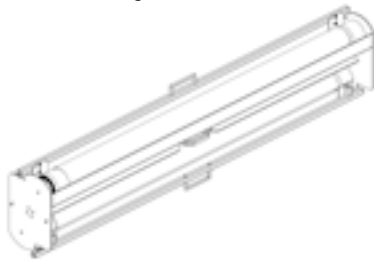

Castor x4



Large Bolt x2



Body Base x1

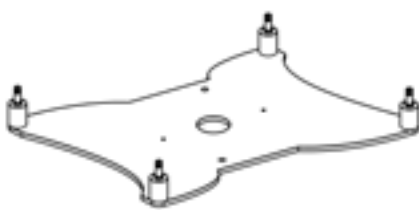

Braked Castor x4



Small Bolt x4



Handle Base x2

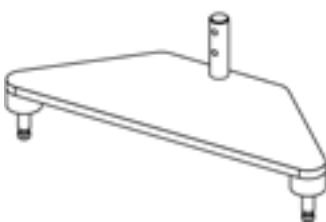

Allen Wrench x1

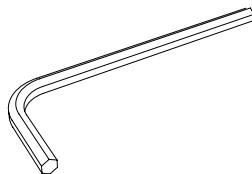

You Will Also need:

13mm Wrench x1

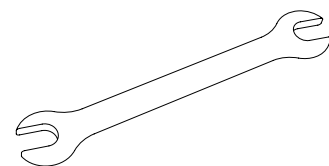

Step 1

- Place the Body Base upside down.
- Install four Braked Castors as shown.

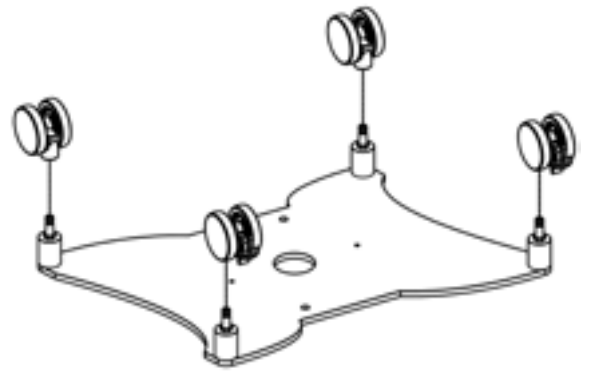
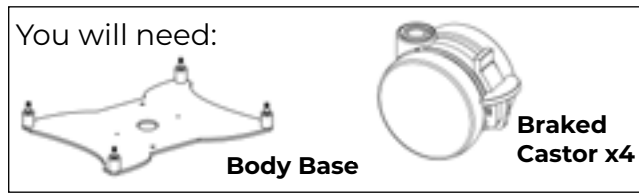

Step 2

- Place the Main body onto the body base, lining up the two bolt holes.
- Insert the two large bolts and tighten using wrench.

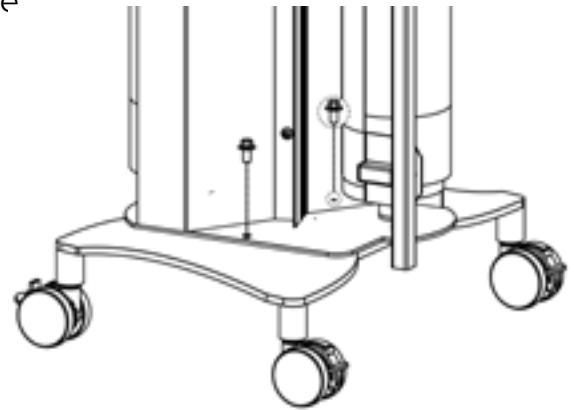
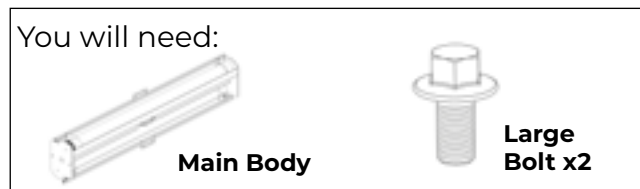

Step 3

- Place the Handle Base upside down.
- Install two Castors as shown.
- Repeat for second handle base.

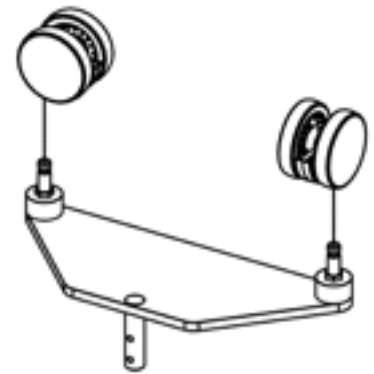

Step 4

- Partially extended one screen panel.
- Insert the Handle base dowel into the handle pole.
- Insert two small bolts into the holes and tighten.
- Repeat for the second screen.

